

SINGLE SHAFT BATCH MIXER



MA/1 – Lt. 1000 in stainless steel



MA/1 – Lt. 2000 in painted carbon steel

Technical Description

The horizontal mixer mod MA/1 – thanks to the particular designing of the batch mixing system based on single shaft ribbon type strongly dimensioned for the hardest uses-assures a perfect mixing of powder and granular materials even with different specific weights and with liquids addition; for these reasons it is used with success in many industrial branches.

MA/1
Ribbon type

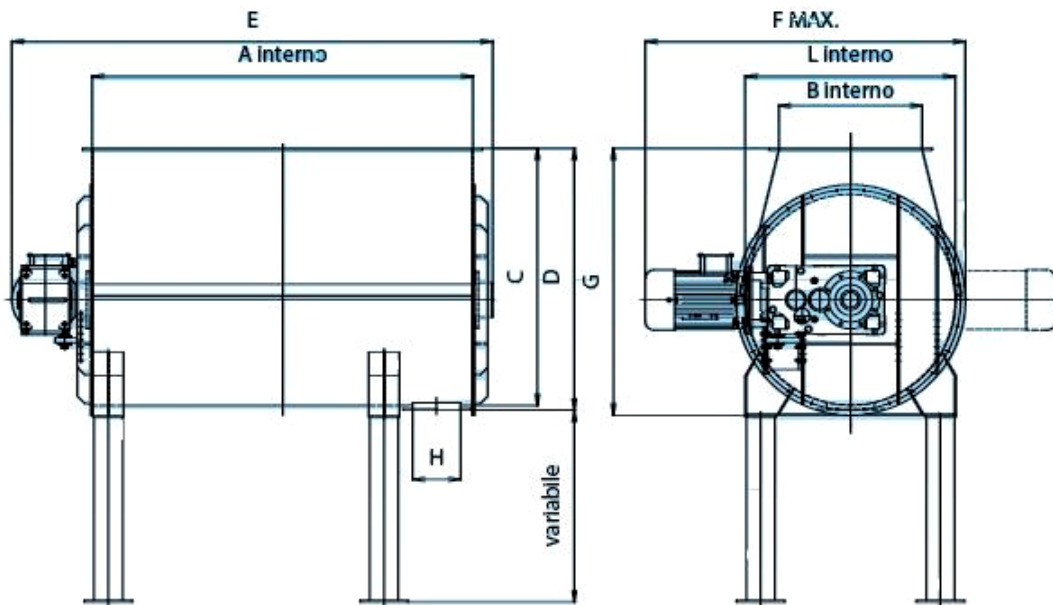

Useful capacity	A	B	C	D	E	F	G	H	L	Power KW	Capacity Kg	Weight Kg
500 lt	1246	745	910	925	1650	950	950	250x250	745	3	250-350	420
1000 lt	1496	650	1080	1095	1980	1330	1125	250x250	900	5,5-7,5	500-700	580
2000 lt	1996	750	1340	1355	2480	1440	1390	250x250	1100	7,5-11	1000-1400	1020

Single Shaft Batch Mixer

FEATURES:

- Useful capacities: litres 200 – 500 – 1000 – 2000.
- Execution in painted carbon steel or stainless steel INOX AISI 304 or AISI 316.
- Direct transmission with right angle shaft gear motor (or with chain transmission).
- Batch mixing system based on a single shaft ribbon type.
- Reduced mixing times.

ACCESSORIES ON REQUEST:

- Unloading valve with pneumatic control.
- Pre-mixing bin.
- Pneumatic bomb door release for quick discharge.
- Under hopper with screw extractor.
- Liquids spraying system with loading cells.
- Digital display or computerized dosing programmers.
- Execution in compliance with ATEX Directive 94/9/EC

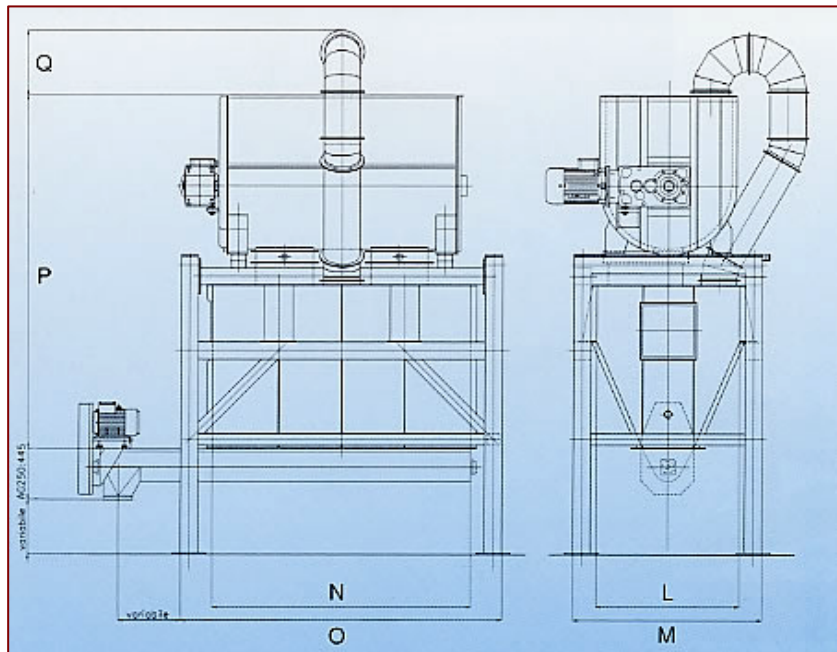

Mixer with under hopper and screw extractor

Useful capacity	L	M	N	O	P	Q
1000 lt	900	1300	1500	1920	2750	480
2000 lt	1100	1550	2000	2550	3250	580

Dimensions (in mm), capacity and technical features are not binding.



Mixer mod MA/1 2000 lt in stainless steel with thermic jacket



Mixer with pneumatic bomb door release for quick discharge

MA/1 – 200 LT. WITH CONTROL PANEL

